

MM-Separator 96 DeepWell

REF MDMG0013

Product description

The MM-Separator 96 DeepWell is designed for fast and efficient collection of magnetic beads in 96 DeepWell microplates. Its SBS footprint allows placement on standard automated liquid handling workstations. Small skirts on each side of the aluminium block ensure correct and stable placement of microplates onto the separator.

Depending on the type of magnetic beads and the suspension media, volumes up to 1.2 mL can be used. Magnetic beads are collected in a ring on the bottom of the microplate wells, allowing safe and easy aspiration of liquids such as samples, wash liquids or eluates in purification protocols. The magnetic separator is designed for U- and V-bottom microplates. It is not recommended for flat-bottom or PCR plates. For PCR plates, the use of MM-Separator 96 PCR (Art.No. MDMG0005) is recommended. Contact magtivio for additional information and compatibility of microplates.

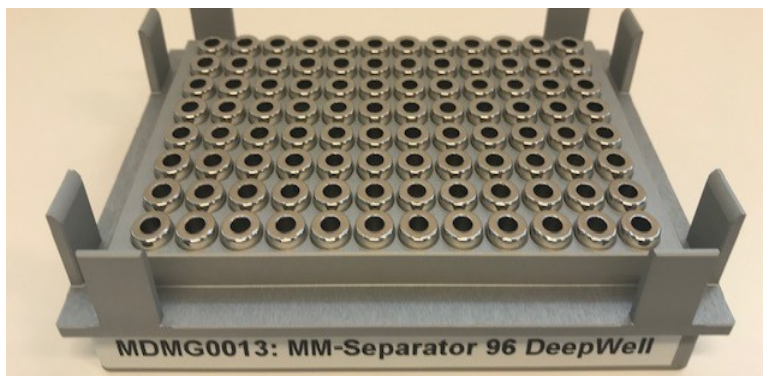

Safety precautions

This magnetic separator contains extremely strong neodymium magnets. Individuals with pacemakers or implantable cardioverter-defibrillators (ICD) should avoid contact with this product. In-vitro studies have shown the potential for interference between strong neodymium magnets and the function of these medical devices (<https://www.ncbi.nlm.nih.gov/pubmed/18334784>).

Do not allow contact with metal objects or other magnets. Under no circumstances, two magnetic separators should be allowed to click together, the magnets are strong enough to cause severe injury and are incredibly difficult to separate. Damage may occur to magnetized media such as credit cards, or to computers or CRT-based monitors near the magnet.

Do not heat above 80°C because this will cause a loss of magnetic strength.

Cleaning

If solutions are spilled onto the MM-Separator 96 DeepWell, rinse the unit with water and gently wipe with a towel

Disclaimer

This product is intended for Research Use Only (RUO).

Warranty information for the accompanying product is available at www.magtivio.com.

The information in this document is subject to change without notice. Magtivio assumes no responsibility for errors that may appear in this document and disclaims all warranties with respect to this document, expressed, or implied, including but not limited to those of merchantability or fitness for a particular purpose.

In no event shall magtivio be liable, whether in contract, tort, warranty, or under any statute or on any other basis for special, incidental, indirect, punitive, multiple or consequential damages in connection with or arising from this document, including but limited to the use thereof.

Specifications

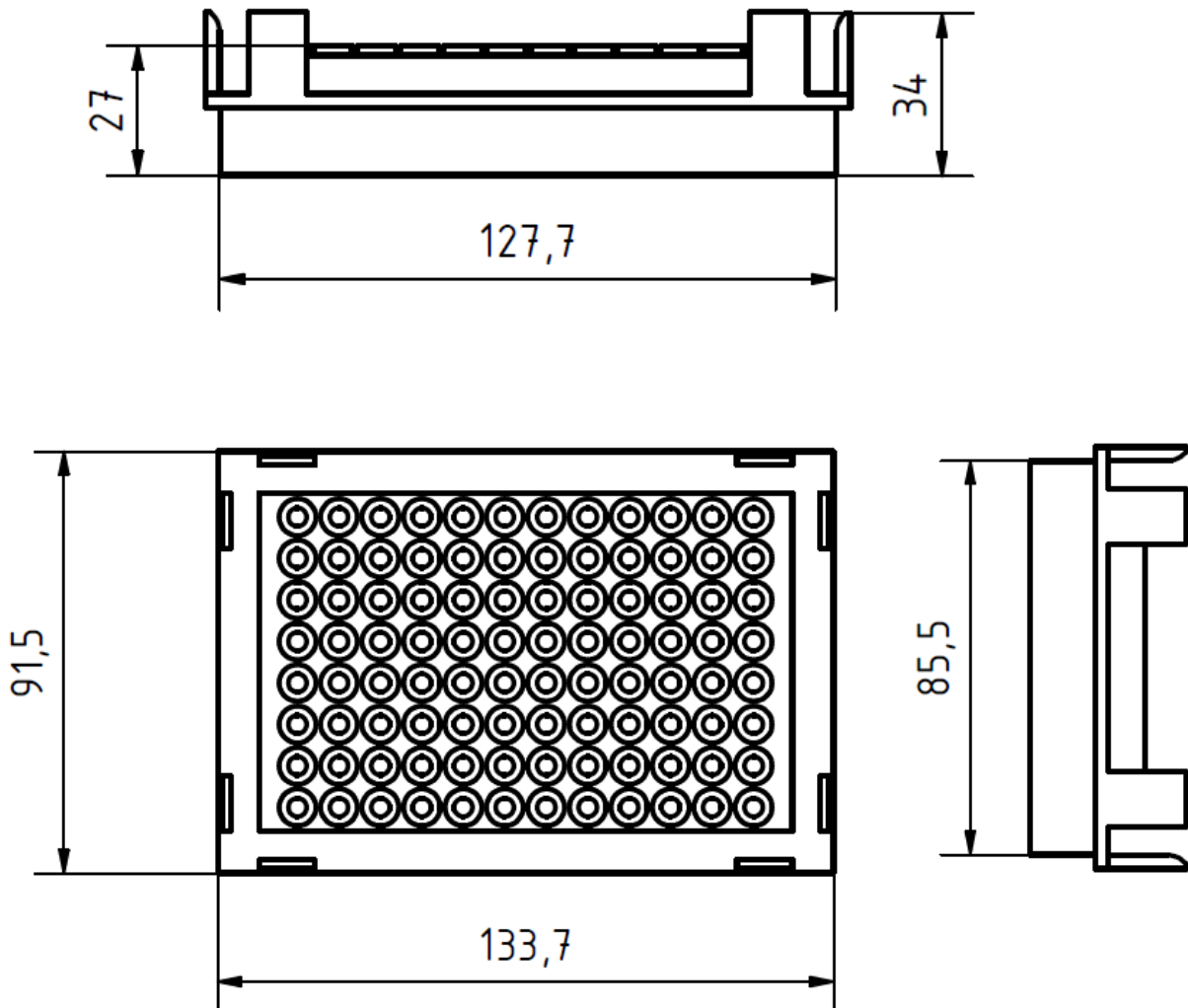

magtivio B.V.

Office, Lab & Production

Daelderweg 9

6361 HK Nuth (The Netherlands)

Tel: +31-(0)45-208 4810

Fax: +31-(0)45-208 4817

E-mail: info@magtivio.com